

County of McHenry Request for Proposal

RFP # 14-59

Services to Provide Maintenance at Water Quality Treatment Structures (Stormceptor)

July 2, 2014

This Request for Proposal (RFP) is for the purpose of, contracting with a qualified firm to provide **Maintenance at Water Quality Treatment Structures (Stormceptor)** as a service to the County of McHenry as outlined within this document. All requirements are as per specifications enclosed herein.

GENERAL REQUIREMENT: This is a Request for Sealed Proposal (see attached). Proposal will be opened and evaluated in private and proposal information will be kept confidential until an award is made. **One (1) original and one (1) copy of the complete proposal are to be submitted.**

SUBMISSION LOCATION:

Mailing Address:

Purchasing Department
McHenry County Administration Building
2200 N. Seminary Avenue Room 200
Woodstock IL 60098

Drop Off In Person:

Purchasing Department
McHenry County Administration Building
667 Ware Road Room 200
Woodstock IL 60098
Phone: (815) 334-4818
Fax: (815) 334-4680

CONTACT PERSON:

Mr. Donald A. Gray, CPPB
Director of Purchasing

SUBMISSION DATE AND TIME:

2:00 PM, (CST) July 31, 2014

Proposals received after the submittal time will be rejected and returned unopened to the sender. (See below for schedule of events).

SCHEDULE OF EVENTS

| | |
|--------------------|--|
| July 3, 2014----- | RFP Available |
| July 11, 2014----- | Vendors Questions Submitted via fax to 815-334-4680 by 4:00 P.M.(CST) |
| July 16, 2014----- | Vendors Questions Answered via fax and Posted on Website by 4:00 P.M.(CST) |
| July 31, 2014----- | RFP due in Purchasing at 2:00 P.M.(CST) |

GENERAL INFORMATION

REQUEST FOR PROPOSALS

DEFINITION

Request for Proposals (RFP) is a method of procurement permitting discussions with responsible vendor and revisions to proposals prior to award of a contract. Proposals will be opened and evaluated in private. **Award** will be based on the criteria set forth herein.

RECEIPT and HANDLING of PROPOSALS

Proposals shall be opened in private by the Evaluation Committee to avoid disclosure of contents to competing vendors.

EVALUATION of PROPOSAL

The proposals submitted by vendors shall be evaluated solely in accordance with the criteria set forth in the RFP.

DISCUSSION of PROPOSAL

The Evaluation Committee may conduct discussions with any offeror who submits an acceptable or potentially acceptable proposal. Vendors shall be accorded fair and equal treatment with respect to any opportunity for discussion and revision of proposals. During the course of such discussions, the Evaluation Committee shall not disclose any information derived from one proposal to any other vendor.

NEGOTIATIONS

The County of McHenry reserves the right to negotiate specifications, terms, and conditions, which may be necessary or appropriate to the accomplishment of the purpose of this RFP. The County may require the RFP and the offeror's proposal be incorporated in full or in part as Contract Documents. This implies that this RFP and all responses, supplemental information, and other submissions provided by the vendor during discussions or negotiations may be held by the County of McHenry as contractually binding on the successful Vendor.

NOTICE of UNACCEPTABLE PROPOSAL

When the Evaluation Committee determines a vendor's proposal to be unacceptable, such vendor shall not be afforded an additional opportunity to supplement its proposal.

TERMS AND CONDITIONS

AUTHORITY

This Request for Proposals is issued pursuant to applicable provisions of the **McHenry County Purchasing Ordinance**, approved December 1, 2006. This ordinance is incorporated by reference into this RFP as if it were contained herein. If you desire a copy of this ordinance, contact the Director of Purchasing.

RESERVED RIGHTS

The County of McHenry reserves the right at any time and for any reason to cancel this Request for Proposal, to reject any or all proposals, or to accept an alternate proposal. The County reserves the right to waive any immaterial defect in any proposal. ***Unless otherwise specified by the offeror, the County has no less than one hundred and twenty (120) days to accept.*** The County may seek clarification from a vendor at any time and failure to respond promptly is cause for rejection. The County may require submission of best and final offers.

INCURRED COSTS

The County of McHenry will not be liable in any way for any costs incurred by respondents in replying to this RFP.

AWARD

Award shall be made by the McHenry County Board to the most responsive and responsible vendor whose proposal is determined to be the most advantageous to the County, taking into consideration price and the evaluation criteria set forth herein below.

CRITERIA for SELECTION

The following criteria and point system shall be used by the selection team to determine the firm or individual(s) most qualified and best suited to perform the work:

1. Qualifications and experience for the specific scope of services as set forth herein (50pts).
2. Cost Proposal based on the contract description (5 pts)
3. Compliance with requirements of this RFP (40 pts).
4. References provided (5 points)

Total 100 points

NON-DISCRIMINATION

Vendor shall comply with the Illinois Human Rights Act, 775 ILCS 5/1-101 et seq., as amended and any rules and regulations promulgated in accordance therewith. Including, but not limited to the Equal Employment Opportunity Clause, Illinois Administrative Code, Title 44, Part 750 (Appendix A), 775 ILCS 5/1-102, which is incorporated herein by reference, and constituting of a written EEO Policy and a workforce profile that demonstrates its EEO practices. Furthermore, the Vendor shall comply the Public Works Employment Discrimination Act, 775 ILCS 10/0.01 et seq., as amended. The Vendor must have a written sexual harassment policy, which meets Illinois State Statutes, 775 ILCS, 15/3.

SECURITY

The Vendor represents and warrants to the County of McHenry that neither it nor any of its principals, shareholders, members, partners or affiliates, as applicable, is a person or entity named as a Specially Designated National and Blocked Person (as defined in Presidential Executive Order 13224) and that it is not acting, directly or indirectly, for or on behalf of a Specially Designated National and Blocked Person. The Vendor further represents and warrants to the County of McHenry that the Vendor and its principals, shareholders, members, partners, or affiliates, as applicable, are not directly or indirectly, engaged in, and are not facilitating, the transactions contemplated by this Agreement on behalf of any person or entity named as Specially Designated National and Blocked Person. The Vendor hereby agrees to defend, indemnify and hold harmless the County of McHenry, the Corporate Authorities, and all County of McHenry elected or appointed officials, officers, employees, agents, representatives, engineers and attorneys, from and against any and all claims, damages, losses, risks, liabilities, and expenses (including reasonable attorneys' fees and costs) arising from or related to any breach of the foregoing representation and warranties.

PREVAILING WAGE

The State of Illinois requires that all wages paid by the Contractor and each subcontractor shall be in compliance with The Prevailing Wage Act (820 ILCS 130), as amended. This requires payment of the general prevailing rate for each craft or type of worker, including payment of the general prevailing rate for legal holiday and overtime work. The Illinois Department of Labor publishes the prevailing wage rates on its website at www.state.il.us/agency/idol/rates.htm. The Contractor shall review the wage rates applicable to the work of the contract at regular intervals in order to ensure the timely payment of current wage rates. The Contractor agrees that no additional notice is required. The Contractor shall be responsible to notify each subcontractor of the wage rates set forth in this contract and any revisions thereto. A copy of the prevailing wage rates is posted on the McHenry County website at www.co.mchenry.il.us under BIDS and RFP's. If wage rates change during the course of the project, the new rates will be available in the County of McHenry Purchasing Office. Vendors may access the Illinois Department of Labor website for updates www.state.il.us/agency/idol.

CERTIFIED PAYROLL REQUIREMENTS (Public Act 94-0515)

Effective August 10, 2005 Vendors and Subcontractors on public works projects must submit certified payroll records on a monthly basis to the public body in charge of the construction project, along with a statement affirming that such records are true and accurate, that the wages paid to each worker are not less than the required prevailing rate and that the Vendor is aware that filing records he or she knows to be false is a Class B misdemeanor.

The certified payroll records must include for every worker employed on the public works project the name, address, telephone number, social security number, job classification, hourly wages paid in each pay period, number of hours worked each day, and starting and ending time of work each day. These certified payroll records are considered public records and public bodies must make these records available to the public under the Freedom of Information Act, with the exception of the employee's address, telephone number, and social security number. Any Vendor who fails to submit a certified payroll or knowingly files a false certified payroll is guilty of a Class B misdemeanor.

INCREASED PENALTIES for PREVAILING WAGE VIOLATIONS (Public Act 94-0488)

Effective January 1, 2006, penalties for violations of the Prevailing Wage Act will increase from 20% to 50% of the underpaid amounts for second or subsequent violations. An additional penalty of 5% of the underpayment penalty must be paid to workers for each month the wages remain unpaid (up from the current 2% penalty).

For violations that occur after January 1, 2006, the debarment period --during which Vendors are ineligible for public works contracts -increases from 2 years to 4 years if two notices of violation are issued/serious violations occur within a 5-year period. In addition, a new monetary penalty of \$5,000 may be assessed against Vendors who retaliate against employees who report violations or file complaints under the Prevailing Wage Act.

OSHA REQUIREMENTS

The Occupational Safety and Health Act of 1970 (OSHA) "guarantees workers the right to a safe and healthful workplace". Under Section 5(a) (1) of the OSHA Act, the employer must "furnish to each of his employees' employment and a place of employment which are free from recognized hazards that are causing or likely to cause death or serious physical harm to his employees."

There are times when the County must hire entities and individuals (contractors) to perform services. To this end, contractors hired by the County of McHenry must perform their duties in a manner that is compliant with all state and federal health and safety laws and industry guidelines. It is the responsibility of the contractor to ensure that their personnel and subcontractors comply with all state and federal health and safety laws and regulations and industry guidelines, including, but not limited to those set forth by: OSHA and related regulations, the Safety Inspection and Education Act, the Health and Safety Act, the National Institute of Occupational Safety and Health, the National Fire Protection Association, the Centers for Disease Control, American Industrial Hygiene Association, the American Council of Governmental Industrial Hygienists, the Environmental Protection Agency, and the Department of Transportation.

SUBSTANCE ABUSE PREVENTION ON PUBLIC WORKS PROJECTS ACT

The successful bidder must be in compliance with State of Illinois HB-1855 (Public Act 095-0635), which amends the Prevailing Wage Act. Before an employer commences work on a public works project, the employer shall have in place a written program, which meets or exceeds the program requirements in this Act, to be filed with the public body engaged in the construction of the public works and made available to the general public, for the prevention of substance abuse among its employees. The testing must be performed by a laboratory that is certified for Federal Workplace Drug Testing Programs by the Substance Abuse and Mental Health Service Administration of the U.S. Department of Health and Human Services.

PROCUREMENT OF GREEN PRODUCTS AND TECHNOLOGIES

As approved by the McHenry County Board in April 2008, it is in the interest of public health, safety and welfare and the conservation of energy and natural resources to use and promote environmentally responsible products. The County should strive to influence private purchases through the example of using government specifications and standards that are green or environmentally friendly when making its purchases.

Whenever available and cost-justified, the County should purchase those materials including the purchase of recycled products containing post-consumer materials rather than residual materials resulting from the processing or manufacturing from another product. To the extent practicable, all products standards shall emphasize functional or performance criteria, which do not discriminate against the use of, recycled materials.

McHenry County should cooperate to the greatest extent feasible with other governments and organizations to develop a comprehensive, consistent, and effective procurement effort intended to stimulate the market for recycled products, reusable products, products designed to be recycled, and other environmentally responsible products.

McHenry County shall continue to participate in and shall encourage other public jurisdictions to participate with the County in the purchase of products containing recycled content. Participation in such cooperative systems shall be aimed at obtaining maximum practical recycled content in County purchases, to obtain best available price for products with recycled content, to facilitate or encourage lower prices industry-wide and to encourage development of industries and markets dealing with recycled content products.

PROCUREMENT OF PRODUCTS THAT ARE ENERGY STAR QUALIFIED

McHenry County shall select, where life cycle and cost-effective, ENERGY STAR and other energy efficient products, when acquiring energy-using products. This information will be required by the bidder in their bid submittal.

PURCHASE EXTENSION

This contract shall be offered for purchases to be made by other counties and governmental units within the State of Illinois as authorized by the Government Joint Purchasing Act. All purchases and payments made under this authority shall be made directly by the governmental unit to the Vendor. The County of McHenry shall not be responsible in any way for such purchase orders or payments. All terms and conditions of this contract shall apply to all orders placed by another governmental unit.

PROTEST PROCEDURES

Any Bidder who believes contractual terms or specifications are unnecessarily restrictive or limit competition may submit a protest, in writing, to the Director of Purchasing. To be considered, the protest must be received by McHenry County five (5) days prior to the stated bid opening. Any adversely affected or aggrieved Bidder shall have ten (10) days from the date of the bid opening to file a written protest regarding the intent to award the bid. Protests submitted after that date will not be accepted. Protests must specify the grounds upon which the protest is based (refer to appropriate statute, rule, code, or ordinance which defines the protest process).

ADDENDUM

Should the Vendor require any additional information about this Bid, please fax to Purchasing (815-334-4680) any questions by the deadline as outlined in the schedule of events. ANY AND ALL changes to these specifications are valid only if they are included by Written Addendum to All Bidders. NO interpretation of the meaning of the plans, specifications, or other contract documents will be made orally. If required, all addenda will be faxed to bidder if a Notice of Intent to Bid has been completed and faxed to the Purchasing Office. In addition, all addenda are posted on the County of McHenry's website. Failure of the bidder to receive any such addendum or interpretation shall not relieve the bidder from obligation under this Bid as submitted. All addenda so issued shall become part of the bid documents. Failure to request an interpretation constitutes a waiver to later claim that ambiguities or misunderstandings caused by a bidder to improperly submit a bid.

Response to these questions will be made by means of an addendum. Only the Director of Purchasing has the authority to issue an addendum.

Addenda are written instruments issued by the County prior to the date for receipt of proposals, which modify or interpret the Bid by addition, deletions, clarifications or corrections.

Prior to the receipt of bids, addenda will be faxed or delivered to all who are known to have received a Notice to Bid. Each vendor shall ascertain prior to submitting a bid that all addenda issued have been received and, by submission of a bid, such act shall be taken to mean that such vendor has received all addenda and that the vendor is familiar with the terms thereof and understands fully the contents of the addenda.

TAXES

The County of McHenry is exempt from paying Illinois Use Tax, Illinois Retailers Occupation Tax, and Federal Excise Tax.

PAYMENTS

The Vendor shall furnish the County with an itemized invoice. Payment shall be made in accordance with applicable provisions of the "Local Government Prompt Payment Act."

VENDOR RESPONSIBILITIES

The selected Vendor will be required to assume responsibility for all services offered in this proposal. The County will consider the selected Vendor to be the sole point of contact with regard to contractual matters, including payment of any and all charges resulting from the contract.

Any contract resulting from this RFP may not be assigned, in whole or in part without written consent of the County. If the Vendor attempts to make such an assignment without the written consent of the County, the Vendor shall nevertheless remain legally responsible for all obligations under the Contract.

INTERPRETATION or CORRECTION of REQUEST for PROPOSALS

Vendors shall promptly notify the Director of Purchasing of any ambiguity, inconsistency, or error, which they may discover upon examination of the Requests for Proposals.

Interpretations, corrections, and changes to the Request for Proposals will be made by addendum. Interpretations, corrections, or changes made in any other manner will not be binding.

COMPLIANCE WITH LAWS

The bidder hereto covenants and agrees to comply with all applicable federal, state, and local laws, codes, ordinances, rules and regulations. Failure to comply with the terms of this provision shall constitute a breach of contract and permit the County to terminate this (Request for Sealed Proposal/Bid) in accordance with the termination provisions stated herein.

RECOURSE for UNSATISFACTORY MATERIALS

Payment shall be contingent upon the County's inspection of and satisfaction with completed work. Any defective work or materials, non-conformance to bid specifications, damaged materials, or unsatisfactory installation shall be corrected to the County's satisfaction by the successful bidder at no additional charge.

TERMINATION

Failure to comply with the terms and conditions as herein stated shall be cause for cancellation of the contract. The County will give written notice of unsatisfactory performance and the Vendor will be allowed thirty (30) days to take corrective action and accomplish satisfactory control. If at the end of the thirty days, the County deems the Vendor's performance still unsatisfactory, the contract shall be canceled. The exercise of its right of cancellations shall not limit the County's right to seek any other remedies allowed by law.

The successful bidder will agree that the resulting contract is made subject to available budgetary appropriations and shall not create any obligation on behalf of the County in

excess of such appropriations. In the event that no funds or insufficient funds are appropriated and budgeted, this Contract shall terminate without penalty or expense to the County thirty (30) days after written notification of termination from the County.

The successful bidder will agree that pursuant to requirements imposed under Illinois law, the County shall have 120 days after each election of county board members to terminate this Agreement, without cause and without penalty.

REJECTION of BIDS, WAIVER of IRREGULARITIES

McHenry County reserves the right to reject any or all bids, to waive irregularities, and to accept that bid which is considered to be in the best interest of the County. Any such decision shall be considered final.

DELIVERY

Delivery will be considered in making the award and the bidders shall state, in the spaces provided expected delivery after receipt of order. Failure to meet said delivery promises without prior consent of the Director of Purchasing will be considered a breach of faith.

WORKMANSHIP

Items shall be manufactured according to the highest traditions of the industry and shall meet all commercial standards of quality. The County shall be the sole judge of acceptable products. Unacceptable products will be rejected and suitable price adjustments made.

QUALIFICATIONS

Each firm submitting an RFP for this project shall submit detailed information concerning the professional qualifications of the individual(s) assigned to carry out this project. Relevant project experience, logistical capabilities and other relevant support data regarding the firm and assigned personnel must be included.

Each firm submitting a proposal for this project must provide at least three (3) references where projects of a similar nature have been successfully completed and implemented. These references should provide the name and address of the entity where the project was completed as well as a contact person.

INSURANCE

General The successful bidder shall maintain for the duration of the contract and any extensions thereof, at bidder's expense, insurance that includes "Occurrence" basis wording and is issued by a company or companies qualified to do business in the State of Illinois that are acceptable to the County, which generally requires that the company(ies) be assigned a Best's Rating of A or higher with a Best's financial size category of Class XIV or higher, in the following types and amounts:

- a) Commercial General Liability in a broad form, to include, but not limited to, coverage for the following where exposure exists: Bodily Injury and Property Damage, Premises/Operations, Independent Vendors, Products/Completed Operations, Personal Injury and Contractual Liability; limits of liability not less than:

\$500,000 per occurrence and \$1,000,000 in the aggregate;

- b) Business Auto Liability to include, but not be limited to, coverage for the following where exposure exists: Owned Vehicles, Hired and Non-Owned Vehicles and Employee Non-Ownership; limits of liability not less than:

\$300,000 per occurrence combined single limit for:
Bodily Injury Liability and Property Damage Liability;

- c) Workers' Compensation Insurance to cover all employees and meet statutory limits in compliance with applicable state and federal laws. The coverage must also include Employer's Liability with minimum limits of \$100,000 for each incident.
- d) Professional Liability Insurance with \$1,000,000 per occurrence and \$1,000,000 in aggregate.

EVIDENCE of INSURANCE

The successful bidder agrees that with respect to the above-required insurance that:

- (a) The County of McHenry shall be provided with Certificates of Insurance evidencing the above required insurance, prior to commencement of the contract and thereafter with certificates evidencing renewals or replacements of said policies of insurance at least fifteen (15) days prior to the expiration or cancellation of any such policies;
- (b) The contractual liability arising out of the contract shall be acknowledged on the Certificate of Insurance by the insurance company;
- (c) The County of McHenry shall be provided with thirty (30) days prior notice, in writing, of Notice of Cancellation or material change and said notification requirement shall be stated on the Certificate of Insurance;
- (d) Subcontractors, if any, comply with the same insurance requirements. In addition to being named as an additional insured on the Certificate of Insurance, each liability policy shall contain an endorsement naming the County of McHenry as an additional insured. A copy of the endorsement shall be provided to McHenry County along with the Certificate of Insurance; and
- (e) have McHenry County named as an additional insured and the address for certificate holder must read exactly as:

County of McHenry, **a body politic**
2200 N. Seminary Avenue
Woodstock, IL 60098

- (f) Insurance Notices and Certificates of Insurance shall be provided to:

McHenry County, Purchasing Department
2200 N. Seminary Avenue, Room 200
Woodstock, Illinois 60098

The County shall be provided with Certificates of Insurance evidencing the above required insurance prior to the commencement of this Agreement and thereafter with the certificated evidencing renewals or changes to said policies of insurance at least fifteen (15) days prior to the expiration or cancellation of any such policies.

The County shall be named as additional insured on all liability policies, and the parties acknowledge that any insurance maintained by the County shall apply in excess of, and not contribute to, insurance provided by successful bidder.

The contractual liability arising out of the Agreement shall be acknowledged on the Certificate of Insurance by the insurance company. The County shall be provided with thirty (30) days prior notice, in writing, of Notice of Cancellation or material change, and said notification requirements shall be stated on the Certificate of Insurance.

Acceptance or approval of insurance shall in no way modify or change the indemnity or hold harmless clauses in this agreement, which shall continue in full force and effect.

HOLD HARMLESS CLAUSE

The Vendor agrees to indemnify, save harmless and defend the County of McHenry, their agents, servants, and employees, and each of them against and hold them harmless from any and all lawsuits, claims, demands, liabilities, losses and expenses, including court costs and attorney's fees, for or on account of any injury to any person, or any death at any time resulting from such injury, or any damage to property, which may arise or which may be alleged to have arisen out of or in connection with the work covered by this contract. The foregoing indemnity shall apply except if such injury, death or damage is caused directly by the willful and wanton conduct of the County of McHenry, their agents, servants, or employees or any other person indemnified hereunder.

CHOICE OF LAW AND VENUE

The bidder agrees that this bid has been executed and delivered in Illinois and that their relationship and any and all disputes, controversies or claims arising under this bid or any resulting contract shall be governed by the laws of the State of Illinois, without regard to conflicts of laws principles. The bidder further agrees that the exclusive venue for all such disputes shall be the Circuit Court of the 22nd Judicial Circuit of McHenry County, Illinois, and the bidder hereby consent to the personal jurisdiction thereof.

EVALUATION

Evaluation of proposals will be done by the Director of Purchasing and associated County staff. Proposals will be evaluated on experience in doing projects of a similar nature and adherence to specifications.

DIRECTIONS FOR SUBMISSION

Qualified individuals or firms are to submit **one (1) original and one (1) copy** of the completed proposal along with any support documentation to:

Mr. Donald A. Gray, CPPB
Director of Purchasing
McHenry County Administration Building
2200 N. Seminary Avenue, Room 200
Woodstock, Illinois 60098

All data and documentation submitted as part of this RFP shall become the property of McHenry County, Illinois. After award of this contract, all responses, documents, and materials contained in the RFP shall be considered public information and will be made available for inspection in accordance with the Illinois Freedom of Information Act.

All proposals must be received by **2:00 p.m. (CST) on July 31, 2014**. Absolutely no proposal will be accepted after the time specified. Late proposals shall be rejected and returned unopened to the sender. The County of McHenry does not prescribe the method by which proposals are to be transmitted; therefore, it cannot be held responsible for any delay, regardless of reason, in the transmission of proposals.

BID ENVELOPES ARE TO BE CLEARLY MARKED WITH THE RFP TITLE, TIME & DATE OF OPENING.

SUBMITTAL

Submit one (1) bid, multiple bids will not be accepted.

PRICING

Price offered shall be firm for at least 120 days after the latest time specified for submission of proposals and thereafter until written notice is received from bidder.

FREIGHT

Freight is all inclusive unless otherwise stated.

FUEL SURCHARGE

The County of McHenry does NOT accept any fuel surcharges.

SCOPE OF WORK

Provide all labor and materials, necessary to provide maintenance for four (4) water quality treatment structures (Stormceptor) for the McHenry County Division of Transportation, per specifications on page 12. This will be a one year bid with a one year option. Year I for 2014 and Option Year II in 2015 and subject to continuing need and availability of funds.

SPECIFICATIONS

WATER QUALITY TREATMENT STRUCTURES (4)

Dewatering, Removal, testing, and proper disposal of all material in water quality treatment structures.

Water quality treatment structures shall be free and clear of any debris, sediment, and contaminants (i.e. oils, hydrocarbons, grease, silt, etc.) upon completion of each maintenance cycle.

Any required traffic control to perform the work as specified

One (1) Visit in Year I (September 2014)

One (1) Visit in Option Year II (June 2015)

48 hour advance notice shall be given to the McHenry County Division of Transportation prior to the commencement of any cleaning activities. Contact to be provided to awardee of this RFP.

LOCATION #1 – 2 Structures at this Location

Alden Road Bridge over Nippersink Creek (Southwest and north east corners of the bridge) located on Alden Road approximately ¼ miles north of Illinois Route 173 in unincorporated Alden Township.

LOCATION # 2

Rakow Road between Pingree Road and Virginia Road, South Row.

LOCATION #3

Randall Road between Ackman and Angella Lane, West Row

MINIMUM QUALIFICATIONS

Respondents shall demonstrate they have the resources and capability to provide maintenance for the four (4) water quality treatment structures as prescribed herein. Plan sheets are attached as a helpful guidance for the cleaning of the four (4) water quality treatment structures (Stormceptor) located at Locations 1, 2 and 3. Failure to meet minimum qualifications is ample cause for the respondent to be deemed non-responsible.

14-6-09 Letting, Item 188

FOR INDEX OF SHEETS, SEE SHEET NO. 2

FEDERAL AID HIGHWAY PROJECT

FAS ROUTE 0026 ALDEN ROAD
BRIDGE AND ROADWAY IMPROVEMENTS

SECTION 02-00269-00-BR
PROJECT BRS-0026(105)
MCHENRY COUNTY
JOB NO. C-91-318-02

PROJECT IS LOCATED IN
THE CITY OF ALDEN

EXISTING STRUCTURE NUMBER: 056-3005
PROPOSED STRUCTURE NUMBER: 056-3174

PROJECT BRS-0026 (105)
PROJECT ENDS
ALDEN ROAD
STATION 125+661

DESCRIPTION OF IMPROVEMENT
THE IMPROVEMENT CONSISTS OF ROADWAY RECONSTRUCTION, BRIDGE RECONSTRUCTION, STORM SEWER AND GRADE SEPARATION, AND ALL INCIDENTAL AND COLLECTIVE WORK AS NECESSARY TO COMPLETE THE IMPROVEMENT DRAWN HEREBY AND AS DESCRIBED IN THE SPECIFICATIONS.

NOTE
1. ALL UTILITY LOCATIONS INFORMATION FOR EXAMINATION
14-609-00-003

CONTRACT NO. 03212

DESIGN DESIGNATION
ALDEN ROAD
2005 ROAD DESIGN
DESIGN SPEED 35 MPH
POSTED SPEED 35 MPH

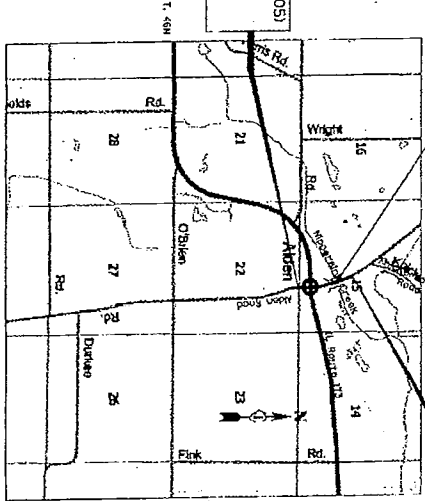

LOCATION MAP
NOT TO SCALE

PROJECT LOCATION (JOB) IS NOT TO SCALE
ALDEN ROAD 2100 FT FROM CENTERLINE

CONTRACT NO. 03212
SECTION 02-00269-00-BR
MCHENRY COUNTY
JOB NO. C-91-318-02

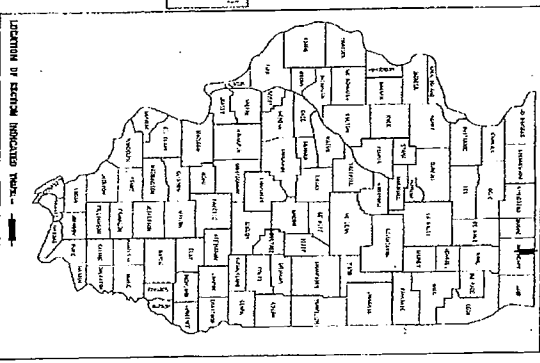

LOCATION OF SECTION INDICATED MAP



DAVID F. BLACK, P.E.
NO. 056-039856
EXP. DATE 11/30/09



JOSEPH L. 0518109
NO. 81-0518109
EXP. DATE 11/20/2010

STATE OF ILLINOIS
DEPARTMENT OF TRANSPORTATION
DIVISION OF HIGHWAYS

APPROVED: *May 26, 2009*

PREPARED BY: *Joseph L. 0518109*

RELATING TO: *BRIDGE AND ROADWAY IMPROVEMENTS*

ROAD NO. *ALDEN ROAD*

PROJECT NO. *02-00269-00-BR*

DATE: *May 26, 2009*

BY: *Joseph L. 0518109*

FOR: *David F. Black*

PRINTED BY THE AUTHORITY
OF THE STATE OF ILLINOIS

| | | | |
|---------|------------|-----|-----|
| PROFILE | DATE | BY | REV |
| NO. 100 | 11/22/2000 | SSM | 1 |
| NO. 100 | 11/22/2000 | SSM | 1 |
| NO. 100 | 11/22/2000 | SSM | 1 |

| | | | |
|---------|------------|-----|-----|
| PLAN | DATE | BY | REV |
| NO. 100 | 11/22/2000 | SSM | 1 |
| NO. 100 | 11/22/2000 | SSM | 1 |
| NO. 100 | 11/22/2000 | SSM | 1 |

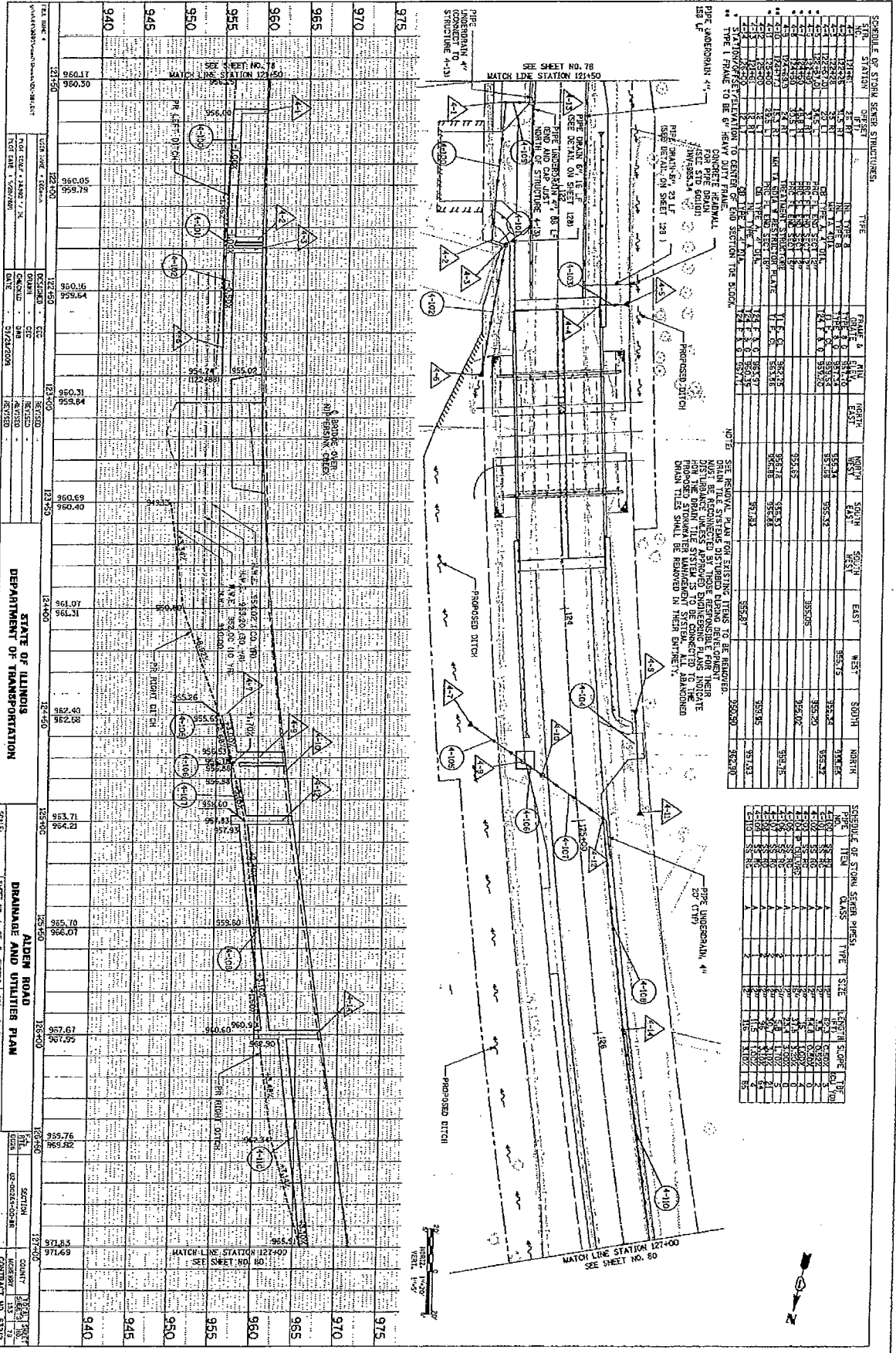

SCHEDULE OF STORM SEWER STRUCTURES

| STATION | DEPTH | TYPE | FRAME # | INVERT | OUTLET | NORTH | SOUTH | WEST | EAST | SOOTH | NORTH |
|---------|-------|---------|---------|--------|--------|--------|--------|--------|--------|--------|--------|
| 121+50 | 2.0 | MANHOLE | 100 | 956.00 | 956.00 | 956.00 | 956.00 | 956.00 | 956.00 | 956.00 | 956.00 |
| 122+00 | 2.0 | MANHOLE | 100 | 955.74 | 955.74 | 955.74 | 955.74 | 955.74 | 955.74 | 955.74 | 955.74 |
| 122+50 | 2.0 | MANHOLE | 100 | 955.16 | 955.16 | 955.16 | 955.16 | 955.16 | 955.16 | 955.16 | 955.16 |
| 123+00 | 2.0 | MANHOLE | 100 | 950.31 | 950.31 | 950.31 | 950.31 | 950.31 | 950.31 | 950.31 | 950.31 |
| 123+50 | 2.0 | MANHOLE | 100 | 960.01 | 960.01 | 960.01 | 960.01 | 960.01 | 960.01 | 960.01 | 960.01 |
| 124+00 | 2.0 | MANHOLE | 100 | 961.79 | 961.79 | 961.79 | 961.79 | 961.79 | 961.79 | 961.79 | 961.79 |
| 124+50 | 2.0 | MANHOLE | 100 | 962.40 | 962.40 | 962.40 | 962.40 | 962.40 | 962.40 | 962.40 | 962.40 |
| 125+00 | 2.0 | MANHOLE | 100 | 953.71 | 953.71 | 953.71 | 953.71 | 953.71 | 953.71 | 953.71 | 953.71 |
| 125+50 | 2.0 | MANHOLE | 100 | 964.21 | 964.21 | 964.21 | 964.21 | 964.21 | 964.21 | 964.21 | 964.21 |
| 126+00 | 2.0 | MANHOLE | 100 | 965.70 | 965.70 | 965.70 | 965.70 | 965.70 | 965.70 | 965.70 | 965.70 |
| 126+50 | 2.0 | MANHOLE | 100 | 967.17 | 967.17 | 967.17 | 967.17 | 967.17 | 967.17 | 967.17 | 967.17 |
| 127+00 | 2.0 | MANHOLE | 100 | 955.76 | 955.76 | 955.76 | 955.76 | 955.76 | 955.76 | 955.76 | 955.76 |
| 127+50 | 2.0 | MANHOLE | 100 | 969.99 | 969.99 | 969.99 | 969.99 | 969.99 | 969.99 | 969.99 | 969.99 |
| 128+00 | 2.0 | MANHOLE | 100 | 971.71 | 971.71 | 971.71 | 971.71 | 971.71 | 971.71 | 971.71 | 971.71 |
| 128+50 | 2.0 | MANHOLE | 100 | 969.71 | 969.71 | 969.71 | 969.71 | 969.71 | 969.71 | 969.71 | 969.71 |

SCHEDULE OF STORM SEWER PIPES

| STATION | DEPTH | TYPE | SIZE | INVERT | SLOPE | COEFF |
|---------|-------|------|------|--------|-------|-------|
| 121+50 | 2.0 | PIPE | 18" | 956.00 | 0.01 | 0.01 |
| 122+00 | 2.0 | PIPE | 18" | 955.74 | 0.01 | 0.01 |
| 122+50 | 2.0 | PIPE | 18" | 955.16 | 0.01 | 0.01 |
| 123+00 | 2.0 | PIPE | 18" | 950.31 | 0.01 | 0.01 |
| 123+50 | 2.0 | PIPE | 18" | 960.01 | 0.01 | 0.01 |
| 124+00 | 2.0 | PIPE | 18" | 961.79 | 0.01 | 0.01 |
| 124+50 | 2.0 | PIPE | 18" | 962.40 | 0.01 | 0.01 |
| 125+00 | 2.0 | PIPE | 18" | 953.71 | 0.01 | 0.01 |
| 125+50 | 2.0 | PIPE | 18" | 964.21 | 0.01 | 0.01 |
| 126+00 | 2.0 | PIPE | 18" | 965.70 | 0.01 | 0.01 |
| 126+50 | 2.0 | PIPE | 18" | 967.17 | 0.01 | 0.01 |
| 127+00 | 2.0 | PIPE | 18" | 955.76 | 0.01 | 0.01 |
| 127+50 | 2.0 | PIPE | 18" | 969.99 | 0.01 | 0.01 |
| 128+00 | 2.0 | PIPE | 18" | 971.71 | 0.01 | 0.01 |
| 128+50 | 2.0 | PIPE | 18" | 969.71 | 0.01 | 0.01 |

STATE OF ILLINOIS
DEPARTMENT OF TRANSPORTATION

ALDEN ROAD
DRAINAGE AND UTILITIES PLAN

SCALE: SHEET NO. 4 OF 5 SHEETS
SHEET NO. 4 OF 5 SHEETS
SHEET NO. 4 OF 5 SHEETS
SHEET NO. 4 OF 5 SHEETS

SCHEDULE OF STORM SEWER STRUCTURES

| STATION | TYPE | FRAME & DIA. | DEPTH | NORTH | EAST | NORTH | EAST | WEST | SOUTH | WEST | NORTH | EAST |
|---------|------|--------------|--------|--------|---------|--------|---------|--------|---------|--------|---------|--------|
| 114+00 | 24" | 12' x 12' | 10'-0" | 114+00 | 979.25 | 114+00 | 979.25 | 114+00 | 979.25 | 114+00 | 979.25 | 114+00 |
| 115+00 | 24" | 12' x 12' | 10'-0" | 115+00 | 981.50 | 115+00 | 981.50 | 115+00 | 981.50 | 115+00 | 981.50 | 115+00 |
| 116+00 | 24" | 12' x 12' | 10'-0" | 116+00 | 983.75 | 116+00 | 983.75 | 116+00 | 983.75 | 116+00 | 983.75 | 116+00 |
| 117+00 | 24" | 12' x 12' | 10'-0" | 117+00 | 986.00 | 117+00 | 986.00 | 117+00 | 986.00 | 117+00 | 986.00 | 117+00 |
| 118+00 | 24" | 12' x 12' | 10'-0" | 118+00 | 988.25 | 118+00 | 988.25 | 118+00 | 988.25 | 118+00 | 988.25 | 118+00 |
| 119+00 | 24" | 12' x 12' | 10'-0" | 119+00 | 990.50 | 119+00 | 990.50 | 119+00 | 990.50 | 119+00 | 990.50 | 119+00 |
| 120+00 | 24" | 12' x 12' | 10'-0" | 120+00 | 992.75 | 120+00 | 992.75 | 120+00 | 992.75 | 120+00 | 992.75 | 120+00 |
| 121+00 | 24" | 12' x 12' | 10'-0" | 121+00 | 995.00 | 121+00 | 995.00 | 121+00 | 995.00 | 121+00 | 995.00 | 121+00 |
| 122+00 | 24" | 12' x 12' | 10'-0" | 122+00 | 997.25 | 122+00 | 997.25 | 122+00 | 997.25 | 122+00 | 997.25 | 122+00 |
| 123+00 | 24" | 12' x 12' | 10'-0" | 123+00 | 999.50 | 123+00 | 999.50 | 123+00 | 999.50 | 123+00 | 999.50 | 123+00 |
| 124+00 | 24" | 12' x 12' | 10'-0" | 124+00 | 1001.75 | 124+00 | 1001.75 | 124+00 | 1001.75 | 124+00 | 1001.75 | 124+00 |
| 125+00 | 24" | 12' x 12' | 10'-0" | 125+00 | 1004.00 | 125+00 | 1004.00 | 125+00 | 1004.00 | 125+00 | 1004.00 | 125+00 |
| 126+00 | 24" | 12' x 12' | 10'-0" | 126+00 | 1006.25 | 126+00 | 1006.25 | 126+00 | 1006.25 | 126+00 | 1006.25 | 126+00 |
| 127+00 | 24" | 12' x 12' | 10'-0" | 127+00 | 1008.50 | 127+00 | 1008.50 | 127+00 | 1008.50 | 127+00 | 1008.50 | 127+00 |
| 128+00 | 24" | 12' x 12' | 10'-0" | 128+00 | 1010.75 | 128+00 | 1010.75 | 128+00 | 1010.75 | 128+00 | 1010.75 | 128+00 |
| 129+00 | 24" | 12' x 12' | 10'-0" | 129+00 | 1013.00 | 129+00 | 1013.00 | 129+00 | 1013.00 | 129+00 | 1013.00 | 129+00 |
| 130+00 | 24" | 12' x 12' | 10'-0" | 130+00 | 1015.25 | 130+00 | 1015.25 | 130+00 | 1015.25 | 130+00 | 1015.25 | 130+00 |

SEE SHEET NO. 77
MATCH LINE STATION 116+00

SEE SHEET NO. 79
MATCH LINE STATION 124+00

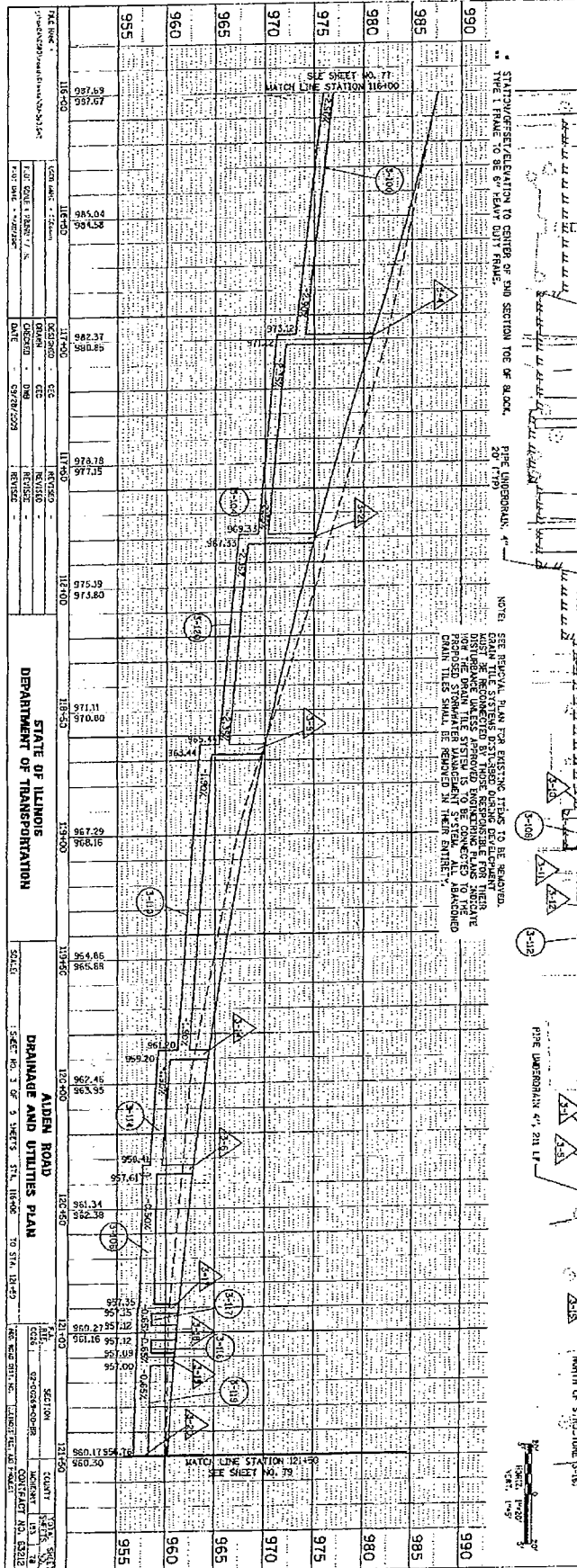

PROFILE

| STATION | FINISH ELEVATION | PIPE TOP ELEVATION |
|---------|------------------|--------------------|
| 114+00 | 997.00 | 985.00 |
| 115+00 | 997.75 | 985.75 |
| 116+00 | 998.50 | 986.50 |
| 117+00 | 999.25 | 987.25 |
| 118+00 | 1000.00 | 988.00 |
| 119+00 | 1000.75 | 988.75 |
| 120+00 | 1001.50 | 989.50 |
| 121+00 | 1002.25 | 990.25 |
| 122+00 | 1003.00 | 991.00 |
| 123+00 | 1003.75 | 991.75 |
| 124+00 | 1004.50 | 992.50 |
| 125+00 | 1005.25 | 993.25 |
| 126+00 | 1006.00 | 994.00 |
| 127+00 | 1006.75 | 994.75 |
| 128+00 | 1007.50 | 995.50 |
| 129+00 | 1008.25 | 996.25 |
| 130+00 | 1009.00 | 997.00 |
| 131+00 | 1009.75 | 997.75 |

STATE OF ILLINOIS
DEPARTMENT OF TRANSPORTATION

ADLEN ROAD
DRAINAGE AND UTILITIES PLAN

SCALE: 1" = 40'
DATE: 11/28/79

131+00
131+50

NOTE: SEE PROFILE PLANS FOR ELEVATION DATA TO BE SHOWN.

PIPE UNDERDRAIN 4" (SEE PROFILE)

PIPE UNDERDRAIN 4" (SEE PROFILE)

PIPE UNDERDRAIN 4" (SEE PROFILE)

PIPE UNDERDRAIN 4" (SEE PROFILE)

PIPE UNDERDRAIN 4" (SEE PROFILE)

PIPE UNDERDRAIN 4" (SEE PROFILE)

(Structure 3-19)
STC 2400 Precast Concrete Stormceptor®
 (2400 U.S. Gallon Capacity)

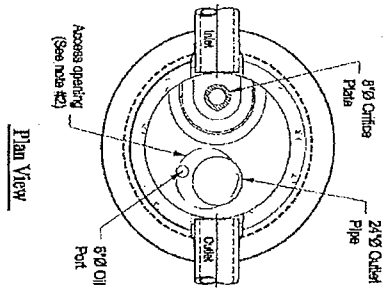
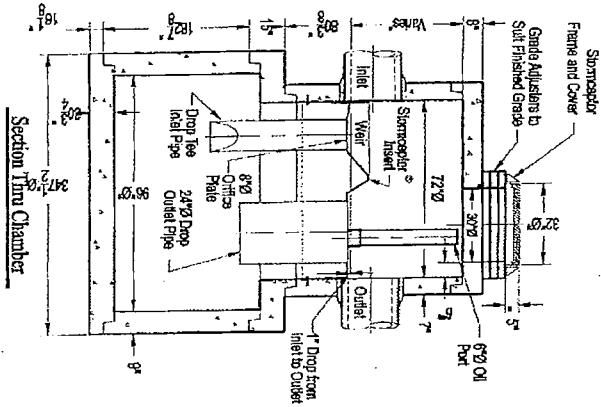

(Structure 4-9)
STC 4500 Precast Concrete Stormceptor®
 (4500 U.S. Gallon Capacity)

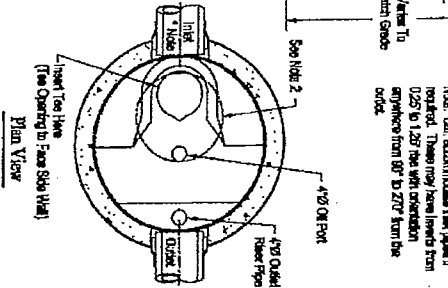
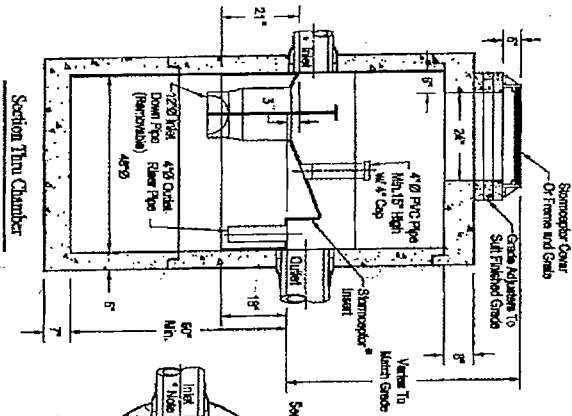

*Note: Our accommodates 1 1/2\"/>

Notes:

1. The Use Of Flexible Connection is Recommended at The Inlet and Outlet Where Applicable.
2. The Cover Should be Positioned Over The Outlet Drop Pipe and The Oil Port.
3. The Stormceptor System is protected by one or more of the following U.S. Patents: #4985148, #5498331, #5725760, #5735115, #5849181, #6068765, #6371690.
4. Contact a Concrete Pipe Division representative for further details not listed on this drawing.

Notes:

1. The Use Of Flexible Connection is Recommended at The Inlet and Outlet Where Applicable.
2. The Cover Should be Positioned Over The Inlet Drop Pipe and The Oil Port.
3. The Stormceptor System is protected by one or more of the following U.S. Patents: #4985148, #5498331, #5725760, #5735115, #5849181, #6068765, #6371690.
4. Contact a Concrete Pipe Division representative for further details not listed on this drawing.

| | | | |
|----------|-------------|-----|---------|
| DATE | DESCRIPTION | BY | CHECKED |
| 12/15/00 | REVISED | ... | ... |
| 01/15/01 | REVISED | ... | ... |
| 03/15/01 | REVISED | ... | ... |
| 05/15/01 | REVISED | ... | ... |
| 07/15/01 | REVISED | ... | ... |
| 09/15/01 | REVISED | ... | ... |
| 11/15/01 | REVISED | ... | ... |
| 01/15/02 | REVISED | ... | ... |
| 03/15/02 | REVISED | ... | ... |
| 05/15/02 | REVISED | ... | ... |
| 07/15/02 | REVISED | ... | ... |
| 09/15/02 | REVISED | ... | ... |
| 11/15/02 | REVISED | ... | ... |
| 01/15/03 | REVISED | ... | ... |
| 03/15/03 | REVISED | ... | ... |
| 05/15/03 | REVISED | ... | ... |
| 07/15/03 | REVISED | ... | ... |
| 09/15/03 | REVISED | ... | ... |
| 11/15/03 | REVISED | ... | ... |
| 01/15/04 | REVISED | ... | ... |
| 03/15/04 | REVISED | ... | ... |
| 05/15/04 | REVISED | ... | ... |
| 07/15/04 | REVISED | ... | ... |
| 09/15/04 | REVISED | ... | ... |
| 11/15/04 | REVISED | ... | ... |
| 01/15/05 | REVISED | ... | ... |
| 03/15/05 | REVISED | ... | ... |
| 05/15/05 | REVISED | ... | ... |
| 07/15/05 | REVISED | ... | ... |
| 09/15/05 | REVISED | ... | ... |
| 11/15/05 | REVISED | ... | ... |
| 01/15/06 | REVISED | ... | ... |
| 03/15/06 | REVISED | ... | ... |
| 05/15/06 | REVISED | ... | ... |
| 07/15/06 | REVISED | ... | ... |
| 09/15/06 | REVISED | ... | ... |
| 11/15/06 | REVISED | ... | ... |
| 01/15/07 | REVISED | ... | ... |
| 03/15/07 | REVISED | ... | ... |
| 05/15/07 | REVISED | ... | ... |
| 07/15/07 | REVISED | ... | ... |
| 09/15/07 | REVISED | ... | ... |
| 11/15/07 | REVISED | ... | ... |
| 01/15/08 | REVISED | ... | ... |
| 03/15/08 | REVISED | ... | ... |
| 05/15/08 | REVISED | ... | ... |
| 07/15/08 | REVISED | ... | ... |
| 09/15/08 | REVISED | ... | ... |
| 11/15/08 | REVISED | ... | ... |
| 01/15/09 | REVISED | ... | ... |
| 03/15/09 | REVISED | ... | ... |
| 05/15/09 | REVISED | ... | ... |
| 07/15/09 | REVISED | ... | ... |
| 09/15/09 | REVISED | ... | ... |
| 11/15/09 | REVISED | ... | ... |
| 01/15/10 | REVISED | ... | ... |
| 03/15/10 | REVISED | ... | ... |
| 05/15/10 | REVISED | ... | ... |
| 07/15/10 | REVISED | ... | ... |
| 09/15/10 | REVISED | ... | ... |
| 11/15/10 | REVISED | ... | ... |
| 01/15/11 | REVISED | ... | ... |
| 03/15/11 | REVISED | ... | ... |
| 05/15/11 | REVISED | ... | ... |
| 07/15/11 | REVISED | ... | ... |
| 09/15/11 | REVISED | ... | ... |
| 11/15/11 | REVISED | ... | ... |
| 01/15/12 | REVISED | ... | ... |
| 03/15/12 | REVISED | ... | ... |
| 05/15/12 | REVISED | ... | ... |
| 07/15/12 | REVISED | ... | ... |
| 09/15/12 | REVISED | ... | ... |
| 11/15/12 | REVISED | ... | ... |
| 01/15/13 | REVISED | ... | ... |
| 03/15/13 | REVISED | ... | ... |
| 05/15/13 | REVISED | ... | ... |
| 07/15/13 | REVISED | ... | ... |
| 09/15/13 | REVISED | ... | ... |
| 11/15/13 | REVISED | ... | ... |
| 01/15/14 | REVISED | ... | ... |
| 03/15/14 | REVISED | ... | ... |
| 05/15/14 | REVISED | ... | ... |
| 07/15/14 | REVISED | ... | ... |
| 09/15/14 | REVISED | ... | ... |
| 11/15/14 | REVISED | ... | ... |
| 01/15/15 | REVISED | ... | ... |
| 03/15/15 | REVISED | ... | ... |
| 05/15/15 | REVISED | ... | ... |
| 07/15/15 | REVISED | ... | ... |
| 09/15/15 | REVISED | ... | ... |
| 11/15/15 | REVISED | ... | ... |
| 01/15/16 | REVISED | ... | ... |
| 03/15/16 | REVISED | ... | ... |
| 05/15/16 | REVISED | ... | ... |
| 07/15/16 | REVISED | ... | ... |
| 09/15/16 | REVISED | ... | ... |
| 11/15/16 | REVISED | ... | ... |
| 01/15/17 | REVISED | ... | ... |
| 03/15/17 | REVISED | ... | ... |
| 05/15/17 | REVISED | ... | ... |
| 07/15/17 | REVISED | ... | ... |
| 09/15/17 | REVISED | ... | ... |
| 11/15/17 | REVISED | ... | ... |
| 01/15/18 | REVISED | ... | ... |
| 03/15/18 | REVISED | ... | ... |
| 05/15/18 | REVISED | ... | ... |
| 07/15/18 | REVISED | ... | ... |
| 09/15/18 | REVISED | ... | ... |
| 11/15/18 | REVISED | ... | ... |
| 01/15/19 | REVISED | ... | ... |
| 03/15/19 | REVISED | ... | ... |
| 05/15/19 | REVISED | ... | ... |
| 07/15/19 | REVISED | ... | ... |
| 09/15/19 | REVISED | ... | ... |
| 11/15/19 | REVISED | ... | ... |
| 01/15/20 | REVISED | ... | ... |
| 03/15/20 | REVISED | ... | ... |
| 05/15/20 | REVISED | ... | ... |
| 07/15/20 | REVISED | ... | ... |
| 09/15/20 | REVISED | ... | ... |
| 11/15/20 | REVISED | ... | ... |

STATE OF ILLINOIS
 DEPARTMENT OF TRANSPORTATION

ALDEN ROAD
 PROJECT DETAILS
 SHEET 2 OF 21

DATE SECTION
 12/15/00 SECTION
 01/15/01 SECTION
 03/15/01 SECTION
 05/15/01 SECTION
 07/15/01 SECTION
 09/15/01 SECTION
 11/15/01 SECTION
 01/15/02 SECTION
 03/15/02 SECTION
 05/15/02 SECTION
 07/15/02 SECTION
 09/15/02 SECTION
 11/15/02 SECTION
 01/15/03 SECTION
 03/15/03 SECTION
 05/15/03 SECTION
 07/15/03 SECTION
 09/15/03 SECTION
 11/15/03 SECTION
 01/15/04 SECTION
 03/15/04 SECTION
 05/15/04 SECTION
 07/15/04 SECTION
 09/15/04 SECTION
 11/15/04 SECTION
 01/15/05 SECTION
 03/15/05 SECTION
 05/15/05 SECTION
 07/15/05 SECTION
 09/15/05 SECTION
 11/15/05 SECTION
 01/15/06 SECTION
 03/15/06 SECTION
 05/15/06 SECTION
 07/15/06 SECTION
 09/15/06 SECTION
 11/15/06 SECTION
 01/15/07 SECTION
 03/15/07 SECTION
 05/15/07 SECTION
 07/15/07 SECTION
 09/15/07 SECTION
 11/15/07 SECTION
 01/15/08 SECTION
 03/15/08 SECTION
 05/15/08 SECTION
 07/15/08 SECTION
 09/15/08 SECTION
 11/15/08 SECTION
 01/15/09 SECTION
 03/15/09 SECTION
 05/15/09 SECTION
 07/15/09 SECTION
 09/15/09 SECTION
 11/15/09 SECTION
 01/15/10 SECTION
 03/15/10 SECTION
 05/15/10 SECTION
 07/15/10 SECTION
 09/15/10 SECTION
 11/15/10 SECTION
 01/15/11 SECTION
 03/15/11 SECTION
 05/15/11 SECTION
 07/15/11 SECTION
 09/15/11 SECTION
 11/15/11 SECTION
 01/15/12 SECTION
 03/15/12 SECTION
 05/15/12 SECTION
 07/15/12 SECTION
 09/15/12 SECTION
 11/15/12 SECTION
 01/15/13 SECTION
 03/15/13 SECTION
 05/15/13 SECTION
 07/15/13 SECTION
 09/15/13 SECTION
 11/15/13 SECTION
 01/15/14 SECTION
 03/15/14 SECTION
 05/15/14 SECTION
 07/15/14 SECTION
 09/15/14 SECTION
 11/15/14 SECTION
 01/15/15 SECTION
 03/15/15 SECTION
 05/15/15 SECTION
 07/15/15 SECTION
 09/15/15 SECTION
 11/15/15 SECTION
 01/15/16 SECTION
 03/15/16 SECTION
 05/15/16 SECTION
 07/15/16 SECTION
 09/15/16 SECTION
 11/15/16 SECTION
 01/15/17 SECTION
 03/15/17 SECTION
 05/15/17 SECTION
 07/15/17 SECTION
 09/15/17 SECTION
 11/15/17 SECTION
 01/15/18 SECTION
 03/15/18 SECTION
 05/15/18 SECTION
 07/15/18 SECTION
 09/15/18 SECTION
 11/15/18 SECTION
 01/15/19 SECTION
 03/15/19 SECTION
 05/15/19 SECTION
 07/15/19 SECTION
 09/15/19 SECTION
 11/15/19 SECTION
 01/15/20 SECTION
 03/15/20 SECTION
 05/15/20 SECTION
 07/15/20 SECTION
 09/15/20 SECTION
 11/15/20 SECTION

FOR INDEX OF SHEETS SEE SHEET NO. 2

HIGHWAY CLASSIFICATION
PRINCIPAL ARTERIAL

RAKOW ROAD TRAFFIC DATA
2005 ADT = 16,500 TO 39,400
2030 ADT = 29,000 TO 66,000
POSTED SPEED LIMIT = 45 MPH
DESIGN SPEED LIMIT = 45 MPH

PROJECT DESCRIPTION
THE PROPOSED IMPROVEMENT CONSISTS OF THE WIDENING AND RECONSTRUCTION OF RAKOW ROAD FROM ACKMAN ROAD TO ILLINOIS ROUTE 31 INCLUDING A NEW STORM SEWER SYSTEM, EXTENSION OF THE CRYSTAL CREEK DOUBLE BOX CULVERT AND TRAFFIC SIGNAL MODERNIZATION

PROJECT LOCATED IN CITY OF CRYSTAL LAKE AND VILLAGE OF LAKE IN THE HILLS.

STATE OF ILLINOIS

DEPARTMENT OF TRANSPORTATION
DIVISION OF HIGHWAYS

PROPOSED HIGHWAY PLANS

FAP 0336 (RAKOW ROAD)
FAU 3873 (ACKMAN ROAD) TO FAP 0336 (ILLINOIS ROUTE 31)
ROADWAY RECONSTRUCTION AND WIDENING
PROJECT #HPP-TCSP-RS-CMF-0336(031)

JOB #C-91-191-05
SECTION #05-00308-00-WR
MCHENRY COUNTY
VOLUME 1

PRAIRIE TRAIL BRIDGE
S.M. 056-9921
STA. 173+34.67

CRYSTAL CREEK CULVERT
S.M. 056-9157
STA. 112+94.31

END PROJECT
STA. 248+17.62

BEGIN PROJECT
STA. 86+42.45

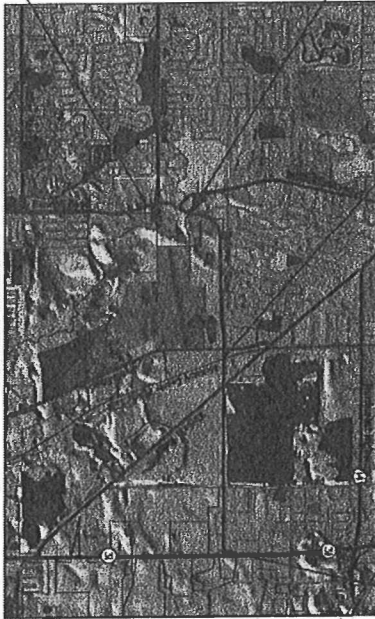

SCALE: 1" = 250'
GROSS & NET LENGTH OF PROJECT = 16,175 FEET (3.06 MILES)

ALGONQUIN TOWNSHIP
LOCATION MAP
R8E

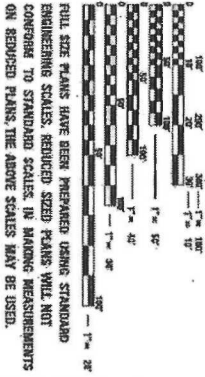

NOTE: FULL SIZE PLANS HAVE BEEN PREPARED USING STANDARD ENGINEERING SCALES. REDUCED SIZE PLANS WILL NOT CONFORM TO STANDARD SCALES. IN MAKING MEASUREMENTS ON REDUCED PLANS, THE ABOVE SCALES MAY BE USED.

CONTRACT NO. 63398

| | | | |
|---|---|---|---|
| <p>PAUL A. HOUSEH, INC. 2005 N. WISCONSIN ST. MCHENRY, IL 60050</p> | <p>PATRICK ENGINEERING, INC. 100 N. WISCONSIN ST. MCHENRY, IL 60050</p> | <p>PATRICK ENGINEERING, INC. 100 N. WISCONSIN ST. MCHENRY, IL 60050</p> | <p>GENERAL CONSULTING ASSOCIATES, INC. 200 N. WISCONSIN ST. MCHENRY, IL 60050</p> |
| <p>ERIC J. COOK, P.E. 052-08311 DATE: 7/26/2010</p> | <p>ERIC J. COOK, P.E. 052-08311 DATE: 7/26/2010</p> | <p>ERIC J. COOK, P.E. 052-08311 DATE: 7/26/2010</p> | <p>ERIC J. COOK, P.E. 052-08311 DATE: 7/26/2010</p> |

| | | |
|--------------------|---------|--------------|
| SECTION | COUNTY | TOTAL SHEETS |
| 05-00308-00-WR | MCHEMRY | 1 |
| CONTRACT NO. 63398 | | |

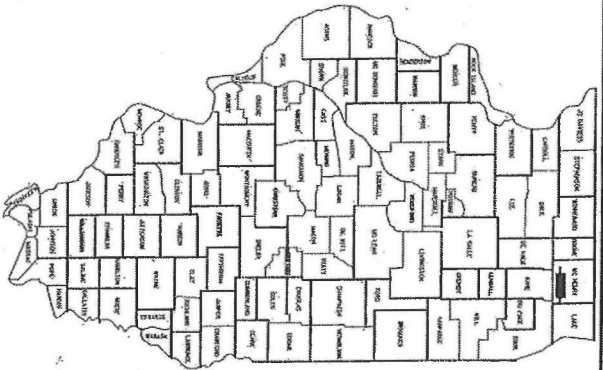

LOCATION OF SECTION INDICATED THERE.

MCHEMRY COUNTY
DIVISION OF TRANSPORTATION

APPROVED: *Stacy A. ...*
DIRECTOR OF TRANSPORTATION / COUNTY ENGINEER

STATE OF ILLINOIS
DEPARTMENT OF TRANSPORTATION
DIVISION OF HIGHWAYS

DISTRICT ENGINEER OF LOCAL ROADS AND STREETS
RELEASING FOR BID BASED ON LIMITED REVIEW

PRINTED BY THE AUTHORITY
OF THE STATE OF ILLINOIS

PLANS PREPARED BY:
PATRICK ENGINEERING, INC.

FINAL

| | | |
|-----------|------|----|
| PLAN | DATE | BY |
| NO. | | |
| DATE | | |
| BY | | |
| FILE NAME | | |

| | |
|-----------|------|
| PROFILE | DATE |
| NO. | |
| DATE | |
| BY | |
| FILE NAME | |

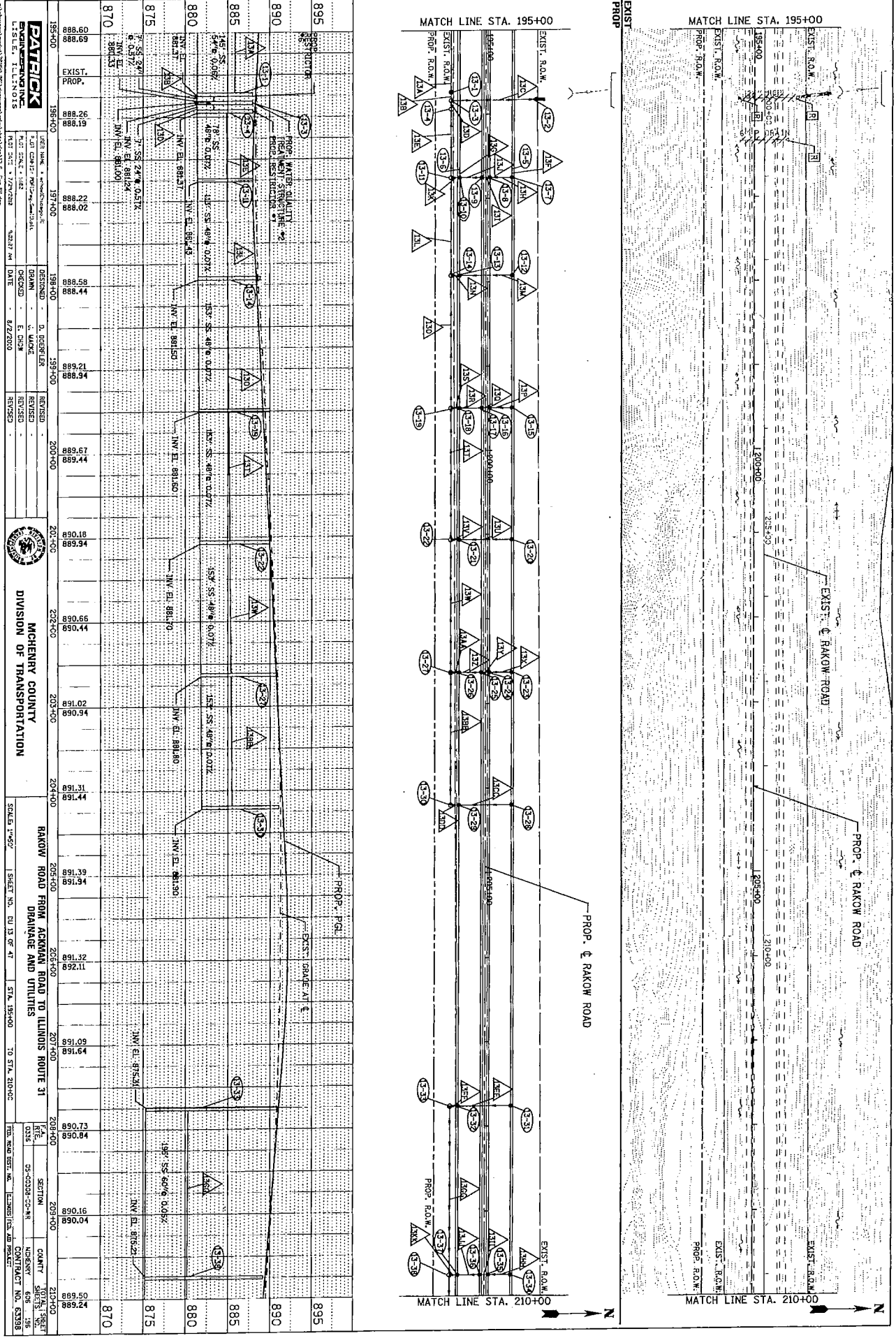

PARTRICK ENGINEERING INC.
 1151 E. ILLINOIS
 CHICAGO, ILLINOIS

DESIGNED BY: D. BERBERER
 CHECKED BY: E. DICK
 DATE: 8/27/00

REVISIONS:
 REVISION 1
 REVISION 2

PROJECT: RAKOW ROAD FROM ASKMAN ROAD TO ILLINOIS ROUTE 31
 SHEET NO. 01 OF 41



MCHEMERY COUNTY
 DIVISION OF TRANSPORTATION

SCALE: 1"=50'

STATIONING: TO STA. 210+00

SECTION: 05-CORR-02-N1

CONTRACT NO. 0338

DATE: 8/27/00

BY: E. DICK

STC 2400 Precast Concrete Stormceptor®
(2400 U.S. Gallon Capacity)

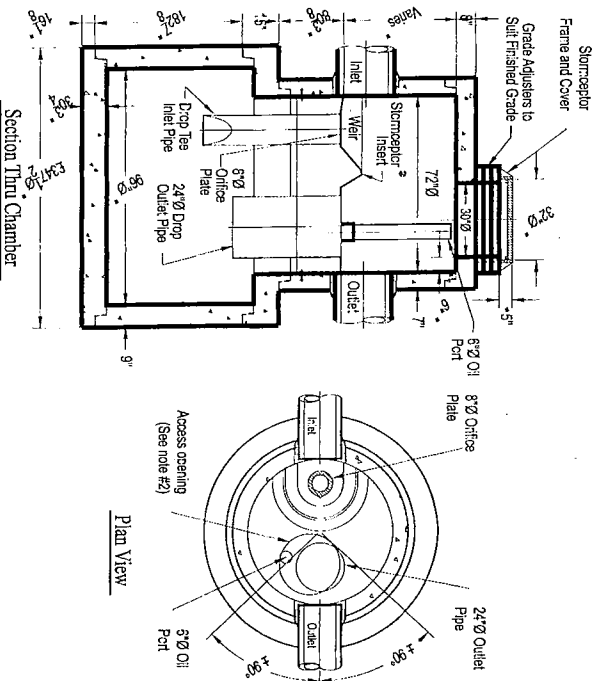

Heaviest Single Piece Wt. Approx. 15,500#

Notes:

1. The Use Of Flexible Connection is Recommended at The Inlet and Outlet Where Applicable.
2. The Cover Should be Positioned Over The Outlet Drop Pipe and The Oil Port.
3. The Stormceptor System is protected by one or more of the following U.S. Patents: #4983148, #5498331, #5725760, #5753115, #5849181, #6068765, #6371690.
4. Contact a Concrete Pipe Division representative for further details not listed on this drawing.

Revised 03/11/11

STC 900 Precast Concrete Stormceptor®
(900 U.S. Gallon Capacity)

Multi Inlet Application

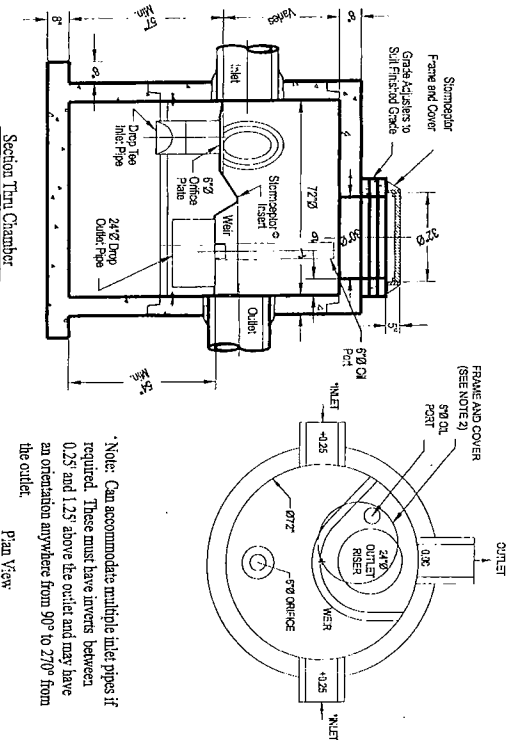

Note: Can accommodate multiple inlet pipes if required. These must have inverters between 0.25' and 1.25' above the outlet and may have an orientation anywhere from 90° to 270° from the outlet.

Notes:

1. The Use Of Flexible Connection is Recommended at The Inlet and Outlet Where Applicable.
2. The Cover Should be Positioned Over The Outlet Drop Pipe and The Oil Port.
3. The Stormceptor System is protected by one or more of the following U.S. Patents: #4983148, #5498331, #5725760, #5753115, #5849181, #6068765, #6371690.
4. Contact a Concrete Pipe Division representative for further details not listed on this drawing.

Revised 04/9/11

WATER QUALITY TREATMENT STRUCTURE #1

WATER QUALITY TREATMENT STRUCTURE #2

| | | | |
|--|--------------------|------------------------|--------------------|
| PATRICK ENGINEERING INC. LITTLE, ILLINOIS | | DESIGNED BY: DUBBERLIS | REVISED BY: - |
| SCALE: 1/8" = 1'-0" | DATE: 8/2/2010 | CHECKED BY: EASON | REVISED BY: - |
| PROJECT: MCHENRY COUNTY DIVISION OF TRANSPORTATION | | SCALE: 1/8" = 1'-0" | SHEET NO. 01 OF 41 |
| PROJECT: RAKOW ROAD FROM ACKMAN ROAD TO ILLINOIS ROUTE 31 DRAINAGE DETAILS | | SCALE: 1/8" = 1'-0" | SHEET NO. 01 OF 41 |
| DATE: 05-03-2008 | CONTRACT NO. 63599 | SCALE: 1/8" = 1'-0" | SHEET NO. 01 OF 41 |

| | | |
|-------------|--|--|
| DATE | | |
| BY | | |
| CHECKED | | |
| DESIGNED | | |
| PLANNED | | |
| PROJECT NO. | | |
| SHEET NO. | | |
| DATE | | |
| BY | | |
| CHECKED | | |
| DESIGNED | | |
| PLANNED | | |
| PROJECT NO. | | |
| SHEET NO. | | |
| DATE | | |

LEGEND:

| BOUNDARY LINES/SYMBOLS | EXISTING | PROPOSED | BOUNDARY LINES/SYMBOLS | EXISTING | PROPOSED |
|----------------------------------|----------|----------|------------------------|----------|----------|
| PERFORMING LINE/CENTERLINE | — | — | MANHOLE | ○ | ○ |
| STORM SEWER | — | — | FLAGGED END SECTION | — | — |
| CATCH BASIN | ○ | ○ | RIGHT OF WAY LINE | — | — |
| HEADWALL/ENDWALL | — | — | TEMPORARY EASEMENT | — | — |
| OPEN JLD MANHOLE/INLET | ○ | ○ | PERMANENT EASEMENT | — | — |
| SMALL SWALE | — | — | DITCH | — | — |
| DETENTION HIGH WATER LEVEL (HWL) | — | — | DITCH CHECK | — | — |
| STORM SEWER REMOVAL | — | — | DITCH LINE | — | — |
| STRUCTURE REMOVAL | — | — | TELEPHONE LINE | — | — |
| STRUCTURE RECONSTRUCTION | — | — | SEWER LINE | — | — |
| STRUCTURE ADJUSTMENT | — | — | SEWER LINE | — | — |
| CUTTER OUTLET | — | — | SANITARY SEWER | — | — |
| WETLAND | — | — | COAXIAL TELEVISION | — | — |
| HYDRANT | — | — | WATER MAIN | — | — |
| ARTICULATED BLOCK REVENUE MAT | — | — | PIPE UNDERPAIN | — | — |
| | | | WATER VALVE | — | — |

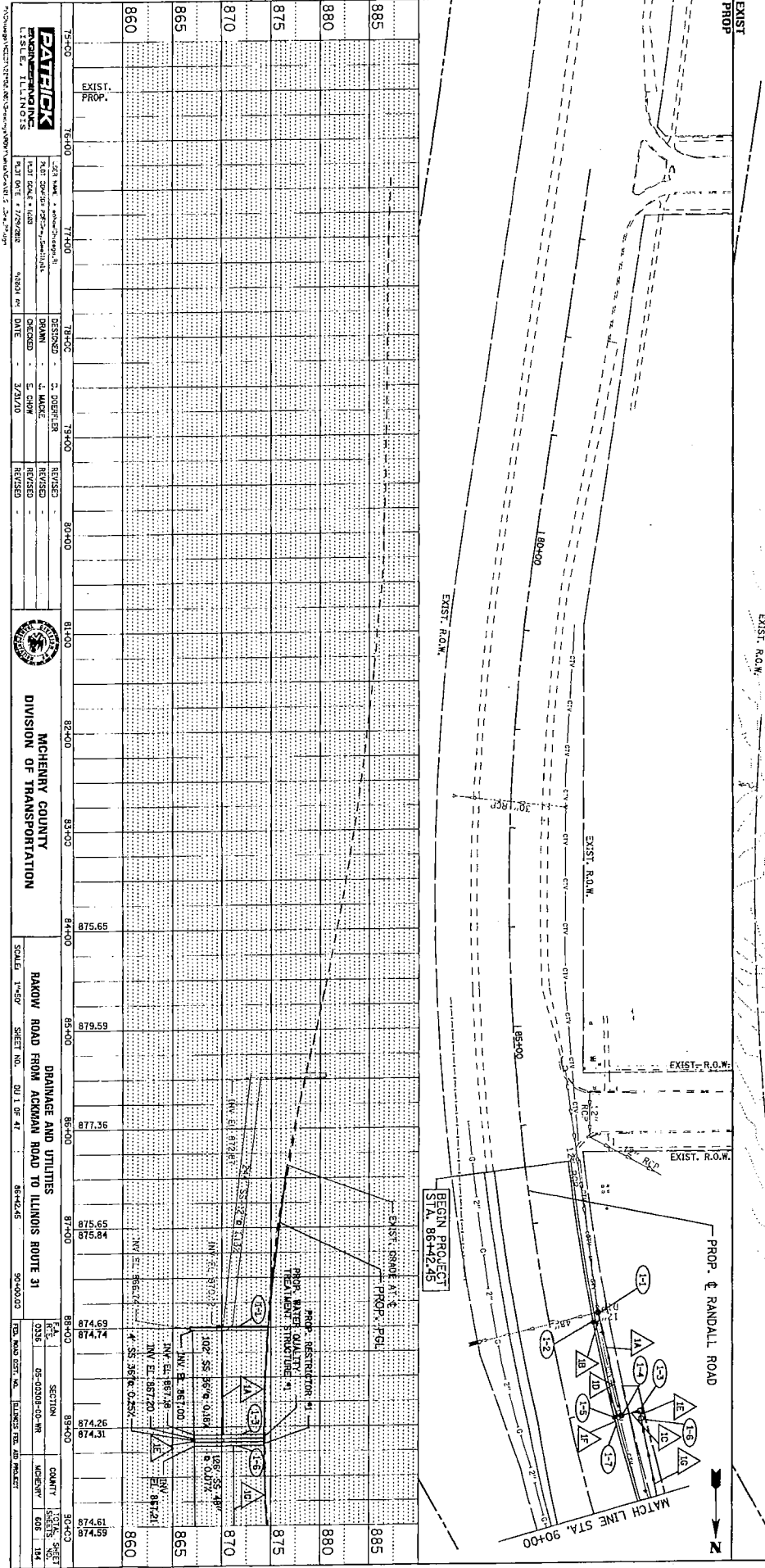

PAVEICK ENGINEERING INC.
 4410 N. ILLINOIS
 LISTEN, ILLINOIS

| | | | |
|----------|------------|----------|--|
| DESIGNED | 2. DEER/18 | REVISION | |
| DRAWN | L. MAGE | REVISION | |
| CHECKED | E. CHOW | REVISION | |
| DATE | 2/28/10 | REVISION | |

MCHENRY COUNTY
 DIVISION OF TRANSPORTATION

RAKOW ROAD FROM ACKMAN ROAD TO ILLINOIS ROUTE 31

SCALE: 1"=50'
 SHEET NO. 01 OF 41

| SECTION | NO. | DATE |
|---------------|-----|----------|
| 05-0300-00-WR | 008 | 08/14/25 |
| 05-0300-00-WR | 104 | 08/14/25 |

RAKOW ROAD FROM ACKMAN ROAD TO ILLINOIS ROUTE 31
 DRAINAGE AND UTILITIES
 SHEET NO. 008 OF 104
 DATE: 08/14/25

THIS PAGE IS MANDATORY.

PROPOSAL FORM

WE, _____, PROPOSE TO PROVIDE THE REQUESTED SERVICES PER THE REQUIREMENTS OF THIS REQUEST FOR PROPOSAL IN ACCORDANCE WITH THE SPECIFICATIONS CONTAINED HEREIN.

| Item Description | YEAR I One (1) Visit – September 2014 | OPTION YEAR II One (1) Visit – June 2015 |
|--|---|--|
| Cost to dewater, remove, test and proper disposal of all material (i.e.: oils, hydrocarbons, Grease, silt, etc.) in the water quality treatment structures (Stormceptor) 4 Structures Total | \$ | \$ |

WE ALSO CERTIFY THAT THIS WRITTEN PROPOSAL IS VALID FOR 120 DAYS FROM THE DAY OF THIS PROPOSAL AND THE ATTACHED INFORMATION IS RECEIVED AND FILED BY THE COUNTY OF MCHENRY.

**Please list below other costs that may be associated with this service or used additional sheets if necessary:

Estimated start date after receipt of purchase order: # _____ days.

Estimated time of completion: # _____ days

REFERENCES

AUTHORIZED NEGOTIATORS:

Name: _____
Phone # _____
Title: _____

Name: _____
Phone # _____
Title: _____

THIS PAGE IS MANDATORY.

List three (3) references that you have done similar work, service or supplied similar products to within the last twelve (12) months (Only correct contact names and phone numbers will be acceptable).

Entity:

Address:

City, State, Zip Code:

Telephone Number:

Contact Person:

Entity:

Address:

City, State, Zip Code:

Telephone Number:

Contact Person:

Entity:

Address:

City, State, Zip Code:

Telephone Number:

Contact Person:

THIS PAGE IS MANDATORY.

**RUBBER STAMPED, FAXED, COPIED, OR TYPED SIGNATURE WILL
DISQUALIFY YOUR BID MUST BE AN ORIGINAL SIGNATURE**

CERTIFICATIONS

Vendor certifies that it has not been barred from contracting with a unit of State or local government as a result of a violation of Section 33E-3 or 33E-4 of the Criminal Code of 1961, as amended. _____ Yes _____ No

Vendor certifies that it is aware that all contracts for the Construction of Public Works are subject to the Illinois Prevailing Wage Act (820 ILCS 130/1-12) _____ Yes _____ No

Under penalties of perjury, I certify that _____ is my correct Federal Taxpayer Identification Number. I am doing business as a (please check one):

- | | |
|---|--|
| <input type="checkbox"/> Individual | <input type="checkbox"/> Real Estate Agent |
| <input type="checkbox"/> Sole Proprietorship | <input type="checkbox"/> Government Entity |
| <input type="checkbox"/> *Partnership | <input type="checkbox"/> Tax Exempt Organization |
| <input type="checkbox"/> **Corporation | (IRC 501(a) only) |
| <input type="checkbox"/> Not-for-Profit Corporation | <input type="checkbox"/> Trust or Estate |
| <input type="checkbox"/> Medical and Health Care Services Provider Corporation | |

*State full names, titles and addresses of all responsible principles and/or partners below;

Name: _____ Title: _____

Address: _____

Name: _____ Title: _____

Address: _____

Name: _____ Title: _____

Address: _____

Name: _____ Title: _____

Address: _____

Name: _____ Title: _____

Address: _____

If needed please submit any additional sheets.

THIS PAGE IS MANDATORY.
PROPOSER'S CERTIFICATION

I have carefully examined the Request for Proposal, Requirements for Statements of Qualifications, Scope of Services Background, and any other documents accompanying or made a part of this Request for Proposal.

I hereby propose to furnish the goods or services specified in the Request for Proposal. I agree that my proposal will remain firm for a period of up to 120 days in order to allow the County adequate time to evaluate the qualifications submitted.

I verify that all information contained in this proposal is truthful to the best of my knowledge and belief. I further certify that I am duly authorized to submit this proposal on behalf of the firm as its act and deed and that the firm is ready, willing and able to perform if awarded the contract.

I further certify, under oath, that this proposal is made without prior understanding, agreement, connection, discussion, or collusion with any other person, firm or corporation submitting a proposal for the same product or service. No officer, employee or agent of the County of McHenry or any other proposer is interested in said proposal and that the undersigned executed this Proposer's Certification with full knowledge and understanding of the matters therein contained and was duly authorized to do so.

**State of Incorporation _____

(Individual - Partnership - Company - Corporation)

(Business Address)

(City, State, and Zip Code)

(By Printed Name and Signature)

(Title)

(Witness Signature)

(Title)

(Telephone No)

(Fax No)

(Date)

End of Document